

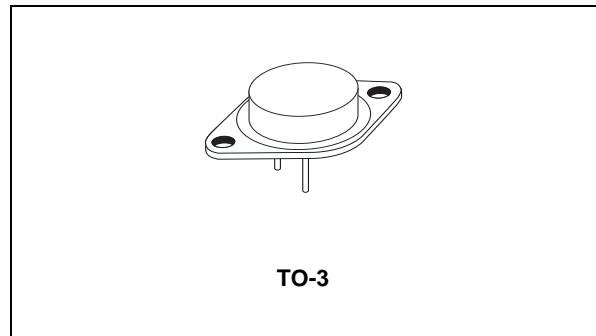

# LM150/LM250 LM350

## THREE-TERMINAL 3 A ADJUSTABLE VOLTAGE REGULATORS

- GUARANTEED 3A OUTPUT CURRENT
- ADJUSTABLE OUTPUT DOWN TO 1.2V
- LINE REGULATION TYPICALLY 0.005%/V
- LOAD REGULATION TYPICALLY 0.1%
- GUARANTEED THERMAL REGULATION
- CURRENT LIMIT CONSTANT WITH TEMPERATURE
- STANDARD 3-LEAD TRANSISTOR PACKAGE



### SCHEMATIC DIAGRAM

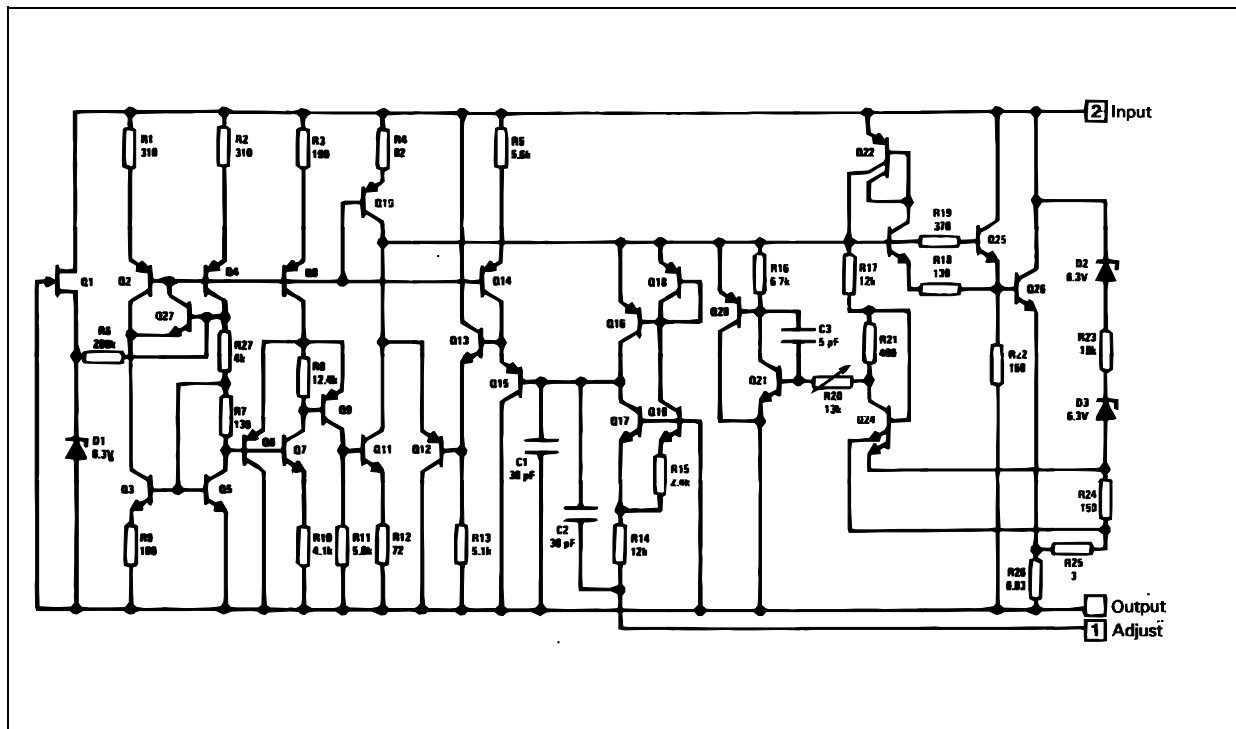

## LM150-LM250-LM350

### ABSOLUTE MAXIMUM RATINGS

Symbol	Parameter	Value	Unit
$P_{tot}$	Power Dissipation	Internally Limited	
$V_I - V_O$	Input-Output Voltage Differential	35	V
$T_{stg}$	Storage Temperature Range	-65 to 150	°C
$T_{lead}$	Lead Temperature (Soldering, 10 seconds)	300	°C
$T_{oper}$	Operating Junction Temperature Range	LM150	-55 to 150
		LM250	-25 to 150
		LM350	0 to 125

Absolute Maximum Ratings are those values beyond which damage to the device may occur. Functional operation under these condition is not implied.

### THERMAL DATA

Symbol	Parameter	Value	Unit
$R_{thj-case}$	Thermal Resistance Junction-case	1.5	°C/W
$R_{thj-amb}$	Thermal Resistance Junction-ambient	35	°C/W

### PIN CONNECTION (Bottom view)

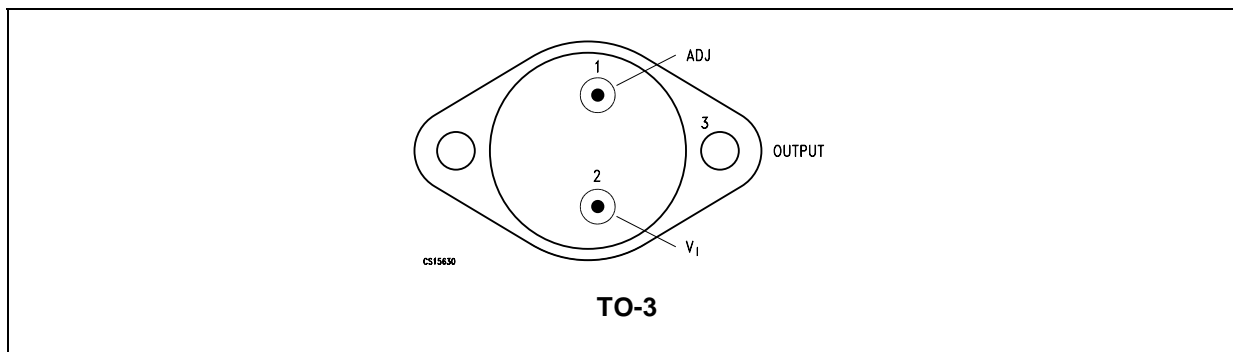

### ORDERING CODES

TYPE	TO-3	TEMPERATURE RANGE
LM150	LM150K	-55°C to 150°C
LM250	LM250K	-25°C to 150°C
LM350	LM350K	0°C to 125°C

**ELECTRICAL CHARACTERISTICS OF LM150/LM250** ( $T_J = -55$  to  $150^\circ\text{C}$  for LM150,  $T_J = -25$  to  $150^\circ\text{C}$  for LM250,  $V_I - V_O = 5\text{V}$ ,  $I_O = 1.5\text{A}$ . Although power dissipation is internally limited, these specifications apply to power dissipation up to  $30\text{W}$ , unless otherwise specified).

Symbol	Parameter	Test Conditions	Min.	Typ.	Max.	Unit
$K_{VI}$	Line Regulation (Note 1)	$T_a = 25^\circ\text{C}$ , $V_I - V_O = 3$ to $35\text{V}$		0.005	0.01	%/V
$K_{VO}$	Load Regulation (Note 1)	$T_a = 25^\circ\text{C}$ $I_O = 10\text{mA}$ to $3\text{A}$	$V_O \leq 5\text{V}$	5	15	mV
			$V_O \geq 5\text{V}$	0.1	0.3	%
	Thermal Regulation	Pulse = $20\text{ms}$		0.002	0.01	%/W
$I_{adj}$	Adjustment Pin Current			50	100	$\mu\text{A}$
$\Delta I_{adj}$	Adjustment Pin Current Change	$I_L = 10\text{mA}$ to $3\text{A}$ $V_I - V_O = 3$ to $35\text{V}$		0.2	5	$\mu\text{A}$
$V_{ref}$	Reference Voltage	$V_I - V_O = 3$ to $35\text{V}$ , $I_O = 10\text{mA}$ to $3\text{A}$ $P \leq 30\text{W}$	1.19	1.24	1.29	V
$K_{VI}$	Line Regulation (Note 1)	$V_I - V_O = 3$ to $35\text{V}$		0.02	0.05	%/V
$K_{VO}$	Load Regulation (Note 1)	$I_O = 10\text{mA}$ to $3\text{A}$	$V_O \leq 5\text{V}$	20	50	mV
			$V_O \geq 5\text{V}$	0.3	1	%
$K_{VT}$	Temperature Stability	$T_J = T_{min}$ to $T_{max}$		1		%
$I_{O(min)}$	Minimum Load Current	$V_I - V_O \leq 35\text{V}$		3.5	5	mA
$I_{O(max)}$	Current Limit	$V_I - V_O \leq 10\text{V}$	DC	3	4.5	A
			$V_I - V_O = 30\text{V}$		1	
$V_{NO}$	RMS Output Noise (% of $V_O$ )	$T_a = 25^\circ\text{C}$ $f = 10\text{Hz}$ to $10\text{KHz}$		0.001		%
$R_{vf}$	Ripple Rejection Ratio	$V_O = 10\text{V}$ , $f = 120\text{Hz}$		65		dB
		$C_{adj} = 10\mu\text{F}$	66	86		
$K_{VH}$	Long Term Stability	$T_a = 125^\circ\text{C}$		0.3	1	%

Note 1: Regulation is measured at constant junction temperature. Changes in output voltage due to heating effects are taken into account separately by thermal rejection.

## LM150-LM250-LM350

**ELECTRICAL CHARACTERISTICS OF LM350** ( $T_J = 0$  to  $150^\circ\text{C}$  for LM150,  $V_I - V_O = 5\text{V}$ ,  $I_O = 1.5\text{ A}$ . Although power dissipation is internally limited, these specifications apply to power dissipation up to  $30\text{W}$ , unless otherwise specified).

Symbol	Parameter	Test Conditions	Min.	Typ.	Max.	Unit
$K_{VI}$	Line Regulation (Note 1)	$T_a = 25^\circ\text{C}$ , $V_I - V_O = 3$ to $35\text{ V}$		0.005	0.03	%/V
$K_{VO}$	Load Regulation (Note 1)	$T_a = 25^\circ\text{C}$ $I_O = 10\text{ mA}$ to $3\text{ A}$	$V_O \leq 5\text{ V}$	5	25	mV
			$V_O \geq 5\text{ V}$	0.1	0.5	%
	Thermal Regulation	Pulse = $20\text{ ms}$		0.002	0.02	%/W
$I_{adj}$	Adjustment Pin Current			50	100	$\mu\text{A}$
$\Delta I_{adj}$	Adjustment Pin Current Change	$I_L = 10\text{ mA}$ to $3\text{ A}$ $V_I - V_O = 3$ to $35\text{ V}$		0.2	5	$\mu\text{A}$
$V_{ref}$	Reference Voltage	$V_I - V_O = 3$ to $35\text{ V}$ , $I_O = 10\text{ mA}$ to $3\text{ A}$ $P \leq 30\text{ W}$	1.19	1.24	1.29	V
$K_{VI}$	Line Regulation (Note 1)	$V_I - V_O = 3$ to $35\text{ V}$		0.02	0.05	%/V
$K_{VO}$	Load Regulation (Note 1)	$I_O = 10\text{ mA}$ to $3\text{ A}$	$V_O \leq 5\text{ V}$	20	70	mV
			$V_O \geq 5\text{ V}$	0.3	1.5	%
$K_{VT}$	Temperature Stability	$T_J = T_{min}$ to $T_{max}$		1		%
$I_{O(min)}$	Minimum Load Current	$V_I - V_O \leq 35\text{ V}$		3.5	10	mA
$I_{O(max)}$	Current Limit	$V_I - V_O \leq 10\text{ V}$	DC	3	4.5	A
			$V_I - V_O = 30\text{ V}$		1	
$V_{NO}$	RMS Output Noise (% of $V_O$ )	$T_a = 25^\circ\text{C}$ $f = 10\text{ Hz}$ to $10\text{ KHz}$		0.001		%
$R_{vf}$	Ripple Rejection Ratio	$V_O = 10\text{ V}$ , $f = 120\text{ Hz}$		65		dB
		$C_{adj} = 10\text{ }\mu\text{F}$	66	86		
$K_{VH}$	Long Term Stability	$T_a = 125^\circ\text{C}$		0.3	1	%

Note 1: Regulation is measured at constant junction temperature. Changes in output voltage due to heating effects are taken into account separately by thermal rejection.

**TYPICAL APPLICATIONS**

1.2V to 25V ADJUSTABLE REGULATOR

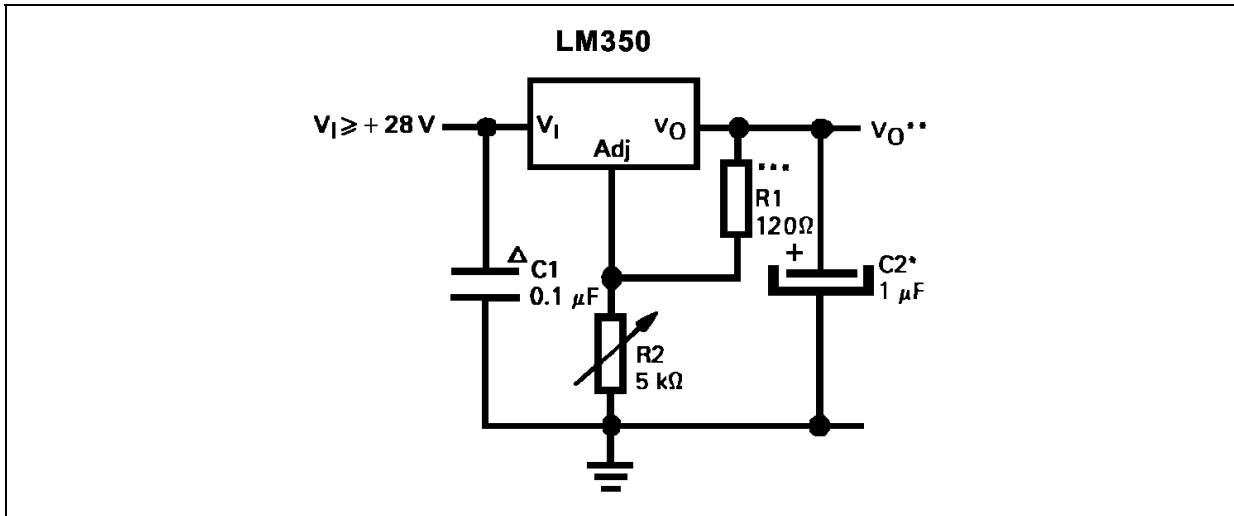

Δ Needed if device is far from filter capacitors.

\* Optional-improves transient response. Output capacitors in the range of 1μF to 100μF of aluminium or tantalum electrolytic are commonly used to provide improved output impedance and rejection of transients

\*\*  $V_O = 1.25V (1 + R_2/R_1)$

\*\*\*  $R_1 = 240\Omega$  for LM150 and LM250

**APPLICATION HINTS**

In operation, the LM350 develops a nominal 1.25V reference voltage,  $V_{(ref)}$ , between the output and adjustment terminal. The reference voltage is impressed across program resistor  $R_1$  and, since the voltage is constant, a constant current  $I_1$  then flows through the output set resistor  $R_2$ , giving an output voltage of

$$V_O = V_{(ref)} (1 + R_2/R_1) + I_{adj}R_2$$

Figure 1 :

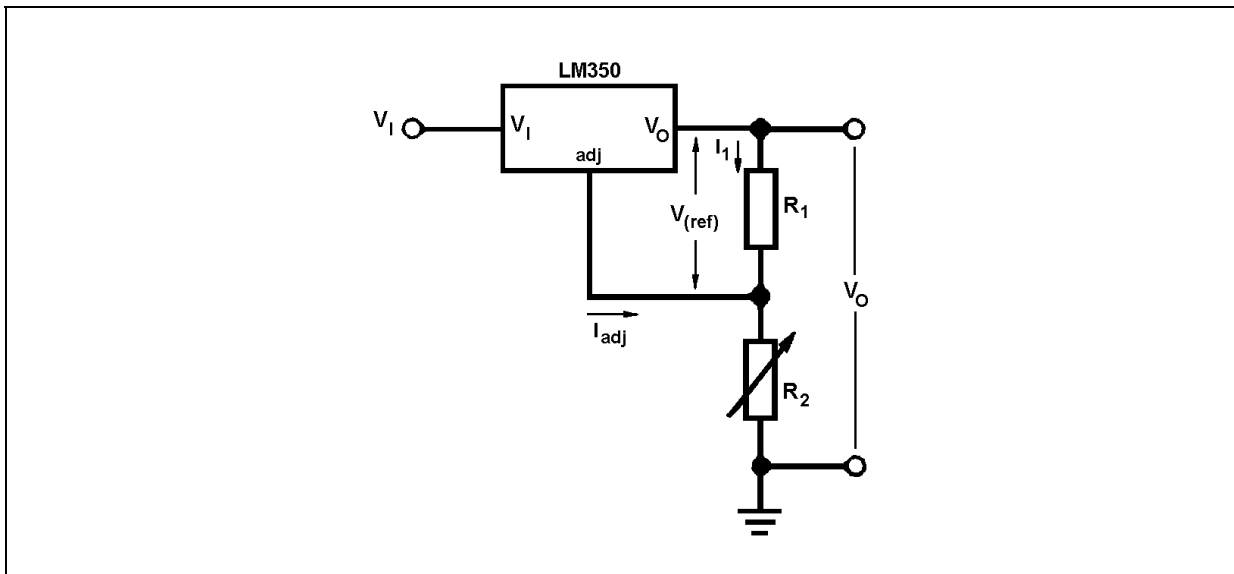

Since the 50μA current from the adjustment terminal represents an error term, the LM350 was designed to minimize  $I_{adj}$  and make it very constant with line and load changes. To do this, all quiescent operating current is returned to the output establishing a minimum load current requirement. If there is insufficient load on the output, the output will rise.

### EXTERNAL CAPACITORS

An input bypass capacitor is recommended. A 0.1 $\mu$ F disc or 1 $\mu$ F solid tantalum on the input is suitable input by passing for almost all applications. The device is more sensitive to the absence of input bypassing when adjustment or output capacitors are used by the above values will eliminate the possibility of problems.

The adjustment terminal can be bypassed to ground on the LM350 to improve ripple rejection. This bypass capacitor prevents ripple from being amplified as the output voltage is increased. With a 10 $\mu$ F bypass capacitor 75dB ripple rejection is obtainable at any output level. Increases over 20 $\mu$ F do not appreciably improve the ripple rejection at frequencies above 120Hz. If the bypass capacitor is used, it is sometimes necessary to include protection diodes to prevent the capacitor from discharging through internal low current paths and damaging the device.

In general, the best type of capacitors to use are solid tantalum. Solid tantalum capacitors have low impedance even at high frequencies. Depending upon capacitor construction, it takes about 25 $\mu$ F in aluminium electrolytic to equal 1 $\mu$ F solid tantalum at high frequencies. Ceramic capacitors are also good at high frequencies, but some types have a large decrease in capacitance at frequencies around 0.5MHz. For this reason, 0.01 $\mu$ F disc may seem to work better than a 0.1 $\mu$ F disc as a bypass.

Although the LM350 is stable with no output capacitors, like any feedback circuit, certain values of external capacitance can cause excessive ringing. This occurs with values between 500pF and 5000pF. A 1 $\mu$ F solid tantalum (or 25 $\mu$ F aluminium electrolytic) on the output swamps this effect and insures stability.

### LOAD REGULATION

The LM350 is capable of providing extremely good load regulation but a few precautions are needed to obtain maximum performance. The current set resistor connected between the adjustment terminal and the output terminal (usually 240 $\Omega$ ) should be tied directly to the output of the regulator rather than near the load. This eliminates line drops from appearing effectively in series with the reference and degrading regulation. For example, a 15V regulator with 0.05 $\Omega$  resistance between the regulator and load will have a load regulation due to line resistance of 0.05 $\Omega$  x IL. If the set resistor is connected near the load the effective line resistance will be 0.05 $\Omega$  (1 + R<sub>2</sub>/R<sub>1</sub>) or in this case, 11.5 times worse.

Figure 2 shows the effect of resistance between the regulator and 140 $\Omega$  set resistor. With the TO-3 package, it is easy to minimize the resistance from the case to the set resistor, by using 2 separate leads to the case. The ground of R<sub>2</sub> can be returned near the ground of the load to provide remote ground sensing and improve load regulation.

### PROTECTION DIODES

When external capacitors are used with any IC regulator it is sometimes necessary to add protection diodes to prevent the capacitors from discharging through low current points into the regulator. Most 20 $\mu$ F capacitors have low enough internal series resistance to deliver 20A spikes when shorted. Although the surge is short, there is enough energy to damage parts of the IC.

When an output capacitor is connected to a regulator and the input is shorted, the output capacitor will discharge into the output of the regulator. The discharge current depends on the value of the capacitor, the output voltage of the regulator, and the rate of decrease of V<sub>I</sub>. In the LM350 this discharge path is through a large junction that is able to sustain 25A surge with no problem. This is not true of other types of positive regulators. For output capacitors of 100 $\mu$ F or less at output of 15V or less, there is no need to use diodes.

The bypass capacitor on the adjustment terminal can discharge through a low current junction. Discharge occurs when either the input or output is shorted. Internal to the LM350 is a 50 $\Omega$  resistor which limits the peak discharge current. No protection is needed for output voltages of 25V or less and 10 $\mu$ F capacitance. Figure 3 shows an LM350 with protection diodes included for use with outputs greater than 25V and high values of output capacitance.

Figure 2 : REGULATOR WITH LINE RESISTANCE IN OUTPUT LEAD

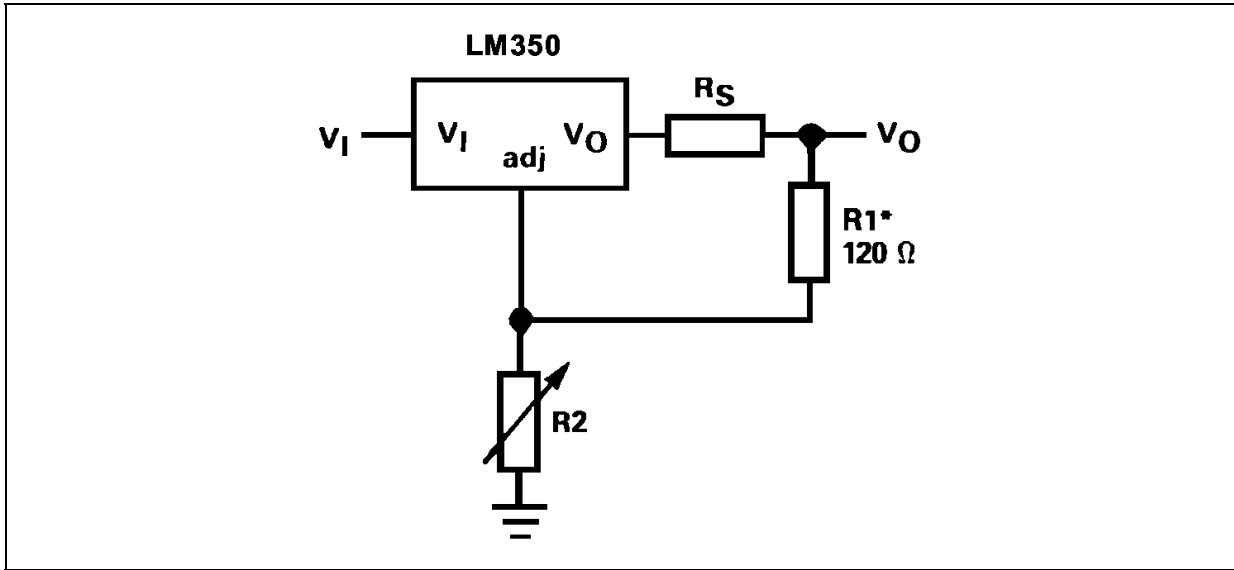
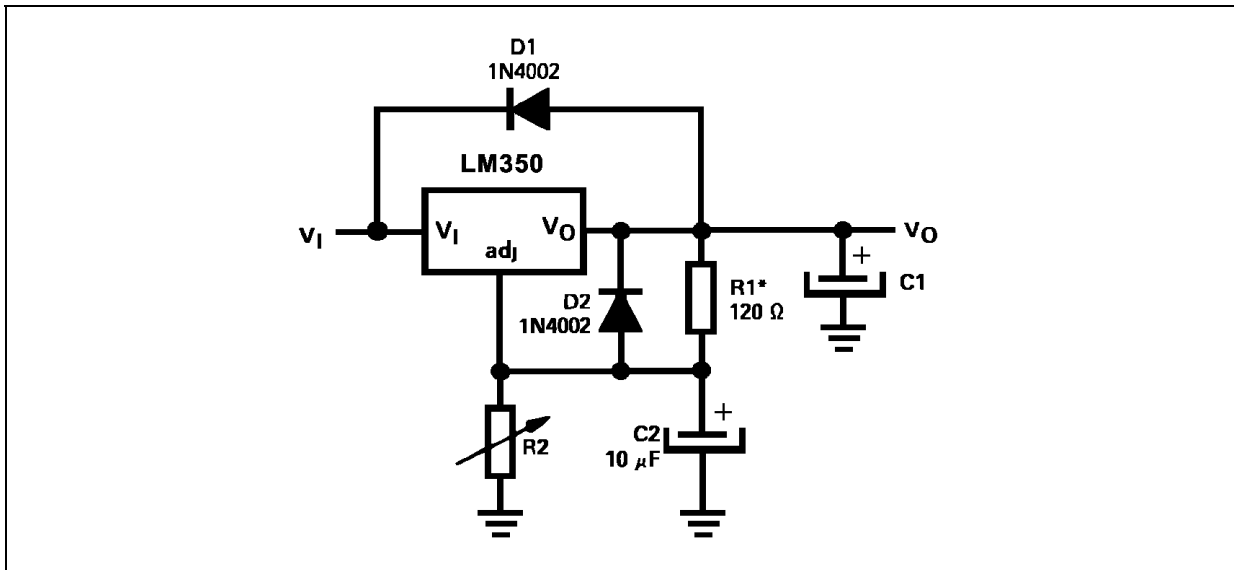
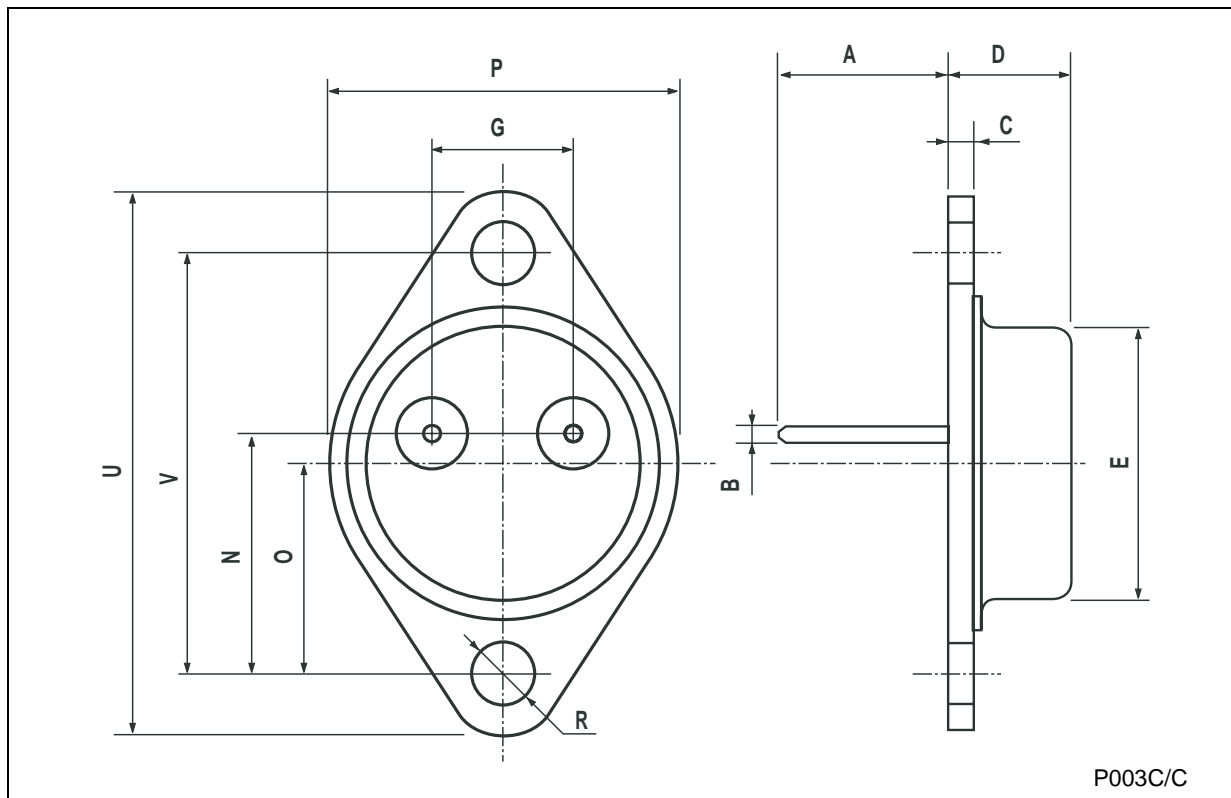

Figure 3 : REGULATOR WITH PROTECTION DIODES



**TO-3 MECHANICAL DATA**

DIM.	mm.			inch		
	MIN.	TYP	MAX.	MIN.	TYP.	MAX.
A		11.85			0.466	
B	0.96	1.05	1.10	0.037	0.041	0.043
C			1.70			0.066
D			8.7			0.342
E			20.0			0.787
G		10.9			0.429	
N		16.9			0.665	
P			26.2			1.031
R	3.88		4.09	0.152		0.161
U			39.5			1.555
V		30.10			1.185	



P003C/C



Information furnished is believed to be accurate and reliable. However, STMicroelectronics assumes no responsibility for the consequences of use of such information nor for any infringement of patents or other rights of third parties which may result from its use. No license is granted by implication or otherwise under any patent or patent rights of STMicroelectronics. Specifications mentioned in this publication are subject to change without notice. This publication supersedes and replaces all information previously supplied. STMicroelectronics products are not authorized for use as critical components in life support devices or systems without express written approval of STMicroelectronics.

© The ST logo is a registered trademark of STMicroelectronics

© 2003 STMicroelectronics - Printed in Italy - All Rights Reserved  
STMicroelectronics GROUP OF COMPANIES

Australia - Brazil - Canada - China - Finland - France - Germany - Hong Kong - India - Israel - Italy - Japan - Malaysia - Malta - Morocco  
Singapore - Spain - Sweden - Switzerland - United Kingdom - United States.

© <http://www.st.com>



This datasheet has been download from:

[www.datasheetcatalog.com](http://www.datasheetcatalog.com)

Datasheets for electronics components.